

► www.birlik-san.com



Birlüksan®

METAL CUTTING & PUNCHING MACHINES

METAL KESME ve DELME MAKİNALARI

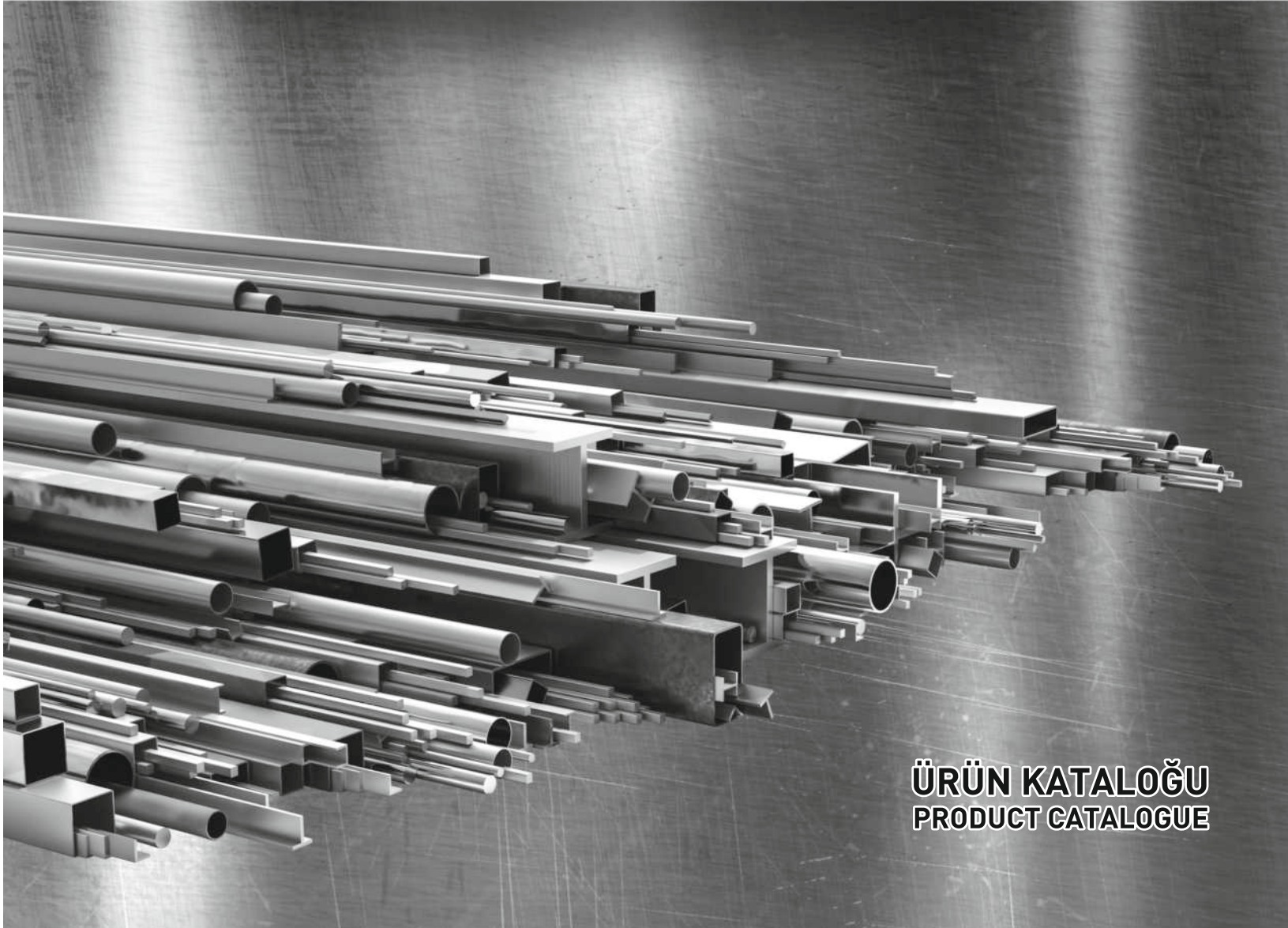

ÜRÜN KATALOĞU
PRODUCT CATALOGUE

BH-125 / HYD-125

HİDROLİK KESME & DELME MAKİNASI

HYDRAULIC CUTTING & PUNCHING MACHINE



Teknik Özellikler Technical Specifications

Makina Detayları / Machine Details		
Motor Gücü / Engine Power	kW	2.2
Motor Voltajı / Engine Voltage	V	380
Ağırlık / Weight	Kg	420
Makine Ölçüleri / Machine Dimensions	LxWxH mm	600x610x1510
Hidrolik Kapasite / Hydraulic Capacity	kN	200
Çalışma Basıncı / Working Pressure	Bar	250
Strok / Stroke	mm	35

Köşebent Kesim / Section and Bar Stock Shear		
Kesit Alanı / Cross Section	Max. mm ²	691
L Köşebent / L Angle Iron	mm	60 x 60 x 6
T Köşebent / T Angle Iron - Optional	mm	50 x 50 x 6
U Köşebent / U Angle Iron - Optional	mm	65 x 42
Yuvarlak / Round	mm	Ø 20
Kare / Square	mm	□ 20
Çalışma Yüksekliği / Working Height	mm	990

Zımbalama / Puncing Unit		
Zımbalama Çapı / Puncing Diameter	Max. mm	Ø26 in 8
Kurs Derinliği / Throat Depth	mm	160
Çalışma Yüksekliği / Working Height	mm	990

Sac - Lama Kesim / Flat Bar Shear		
Lama Demir / Flat Bar	mm	180 x 8
Çalışma Yüksekliği / Working Height	mm	820

- Flat bar shear blades, 185 mm wide, also shearing angle iron 45°
- Material Support table on the flat bar shear station
- Material Support table on the punch unit
- Section shear station for shearing angle iron, rounds and squares.
- Easy-to-change punch & die set
- Foot switch and electrical controls
- Connecting socket for remote tripping, e.g. electrical length stop
- Hydraulic power-pack with a charge of fluid
- Three-phase A.C. motor 380V 50Hz
- All performance data are based on a tensile strength of 450 N/mm².

Özel Projeler için Lütfen bilgi alınız.
Please contact for Special Projects.



8mm Malzeme Kalınlığına Kadar Delik Delme Tablası
Punching Table Up To 8mm Material Thickness

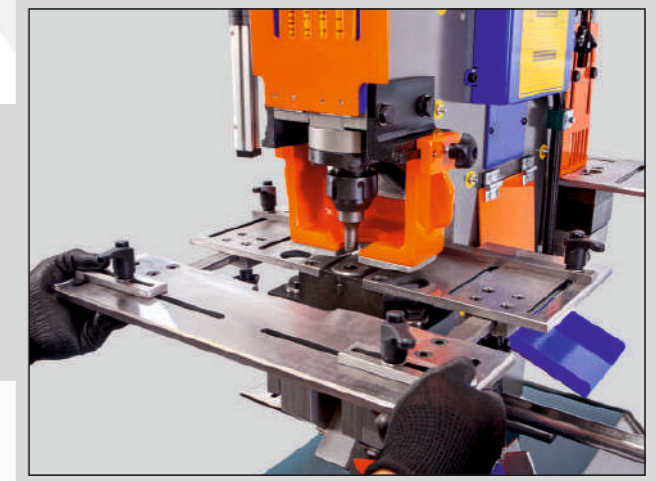

Çıkarılabilir Ön Tabla Tasarımı
Removable Front Table Design

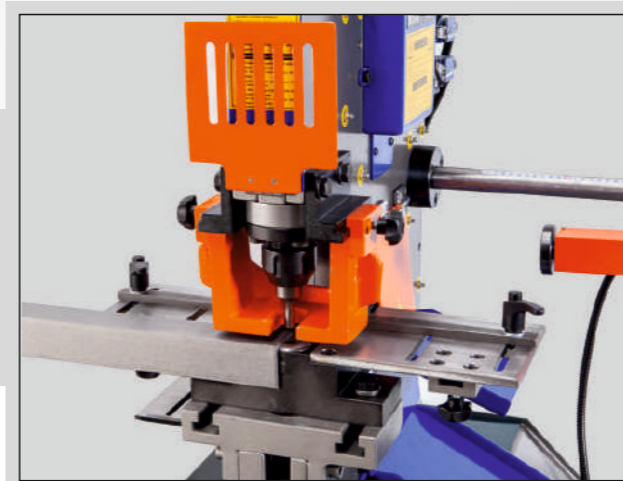

Köşebent Alından Delme
Angle Iron Punching

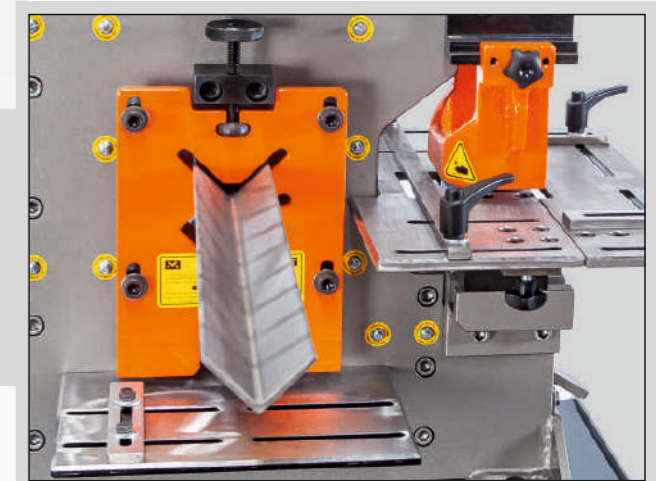

Köşebent Ve Lama Kesim Bölümü
Angle And Flat Iron Cutting Section

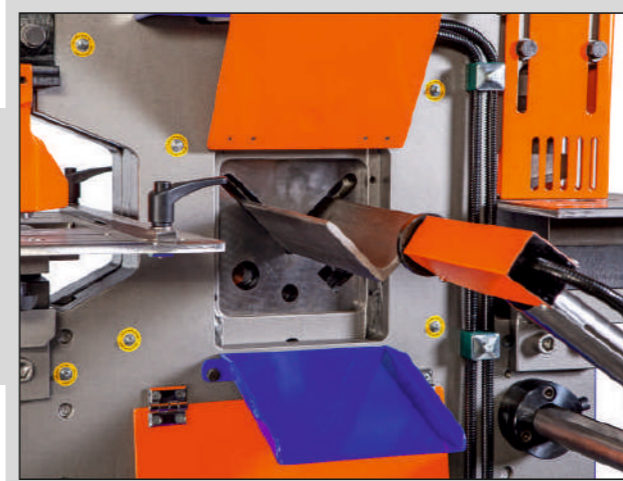

Cetveli Yarı-Otomatik Boy Kesme Aparatı
Semi- Automatic Length Cutting Apparatus With Ruler

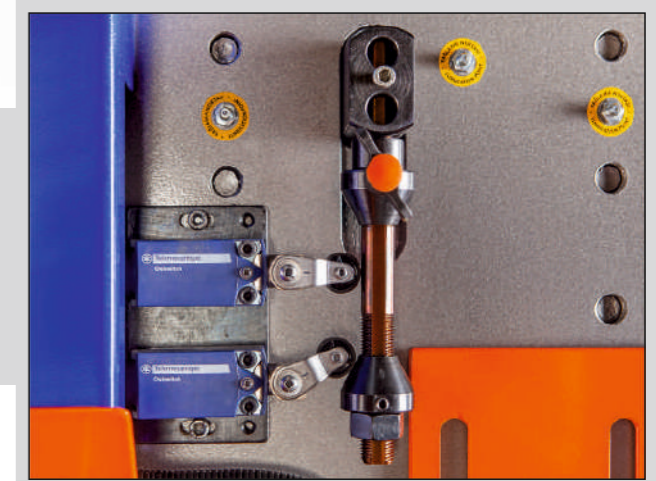

Telemecanique Siviçli Strok Ayar Sistemi
Stroke Adjustment System With Telemecanique Switch

BH-360 / HYD-360

HİDROLİK KESME & DELME MAKİNASI

HYDRAULIC CUTTING & PUNCHING MACHINE



Teknik Özellikler Technical Specifications

Makina Detayları / Machine Details		
Motor Gücü / Engine Power	kW	4
Motor Voltajı / Engine Voltage	V	380
Ağırlık / Weight	Kg	800
Makine Ölçüleri / Machine Dimensions	LxWxH mm	680x860x1820
Hidrolik Kapasite / Hydraulic Capacity	kN	400
Çalışma Basıncı / Working Pressure	Bar	250
Strok / Stroke	mm	50

Köşebent Kesim / Section and Bar Stock Shear		
Kesit Alanı / Cross Section	Max. mm ²	1230
L Köşebent / L Angle Iron	mm	80 x 80 x 8
T Köşebent / T Angle Iron - Optional	mm	70 x 70 x 7
U Köşebent / U Angle Iron - Optional	mm	100 x 50
I Köşebent / I Angle Iron - Optional	mm	100 x 50
Yuvarlak / Round	mm	Ø 30
Kare / Square	mm	□ 28
Çalışma Yüksekliği / Working Height	mm	1200

Zımbalama / Puncing Unit		
Zımbalama Çapı / Puncing Diameter	mm	Ø 30 in 10
Kurs Derinliği / Throat Depth	mm	160
Çalışma Yüksekliği / Working Height	mm	1250

Sac - Lama Kesim / Flat Bar Shear		
Lama Demir / Flat Bar	Max. mm	150 x 12
Çalışma Yüksekliği / Working Height	mm	960

Çentik / Notcher		
Sac / Sheet Metal	mm	8
Çentik Eni / Notch Width	mm	60
Çentik Derinliği / Notch Depth	mm	54
Üçgen Çentik / Triangle Notcher (Optional)	mm	60 x 60 x 6
Çalışma Yüksekliği / Working Height	mm	1250

Bükme / Bending Tools (Opsiyonel/Optional)		
Lama / Flat	Max. mm	100 x 10
Bükme Ucu / Bending Punch	mm	60°, R=8
Bükme Kalıbı / Bending Die	mm	85°, R=8
Çalışma Yüksekliği / Working Height	mm	1250

- Material Support table on the notcher station
- Material Support table on the flat bar shear station
- Material Support table on the punch unit
- Section shear station for shearing angle iron, rounds and squares.
- Easy-to-change punch & die set
- Foot switch and electrical controls
- Connecting socket for remote tripping, e.g. electrical length stop
- Hydraulic power-pack with a charge of fluid
- Three-phase A.C. motor 380V 50Hz
- All performance data are based on a tensile strength of 450 N/mm².

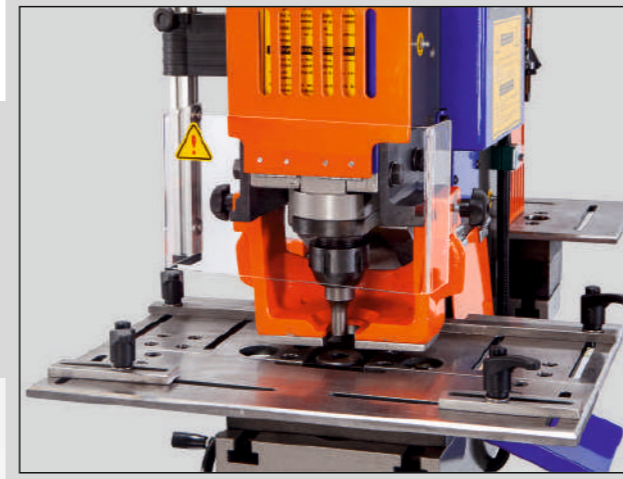

10mm Malzeme Kalınlığına Kadar Delik Delme Tablası
Punching Table Up To 10mm Material Thickness

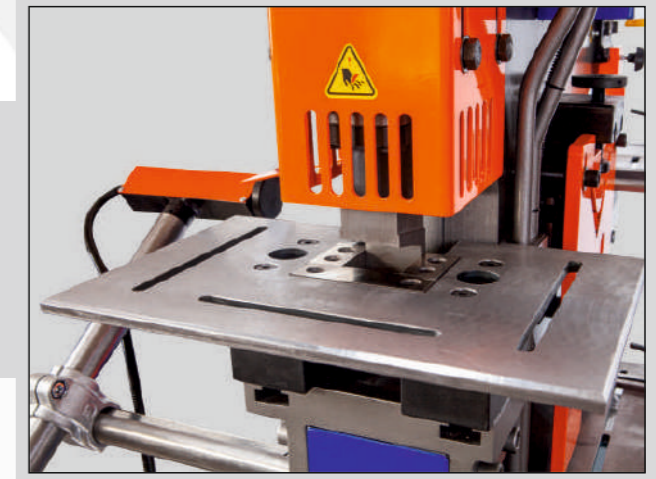

Kare Ve Üçgen Çentik Açma Bölümü
Square And Triangle Notcher Section



Lama Kesim Bölümü
Flat Iron Cutting Section



Köşebent Ve Npu Kesim Bölümü
Angle Iron And Npu Cutting Section

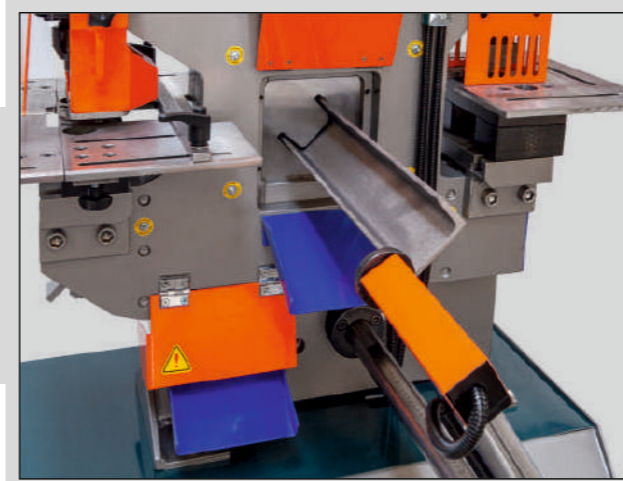

Cetveli Yarı-Otomatik Boy Kesme Aparatı
Semi-Automatic Length Cutting Apparatus With Ruler

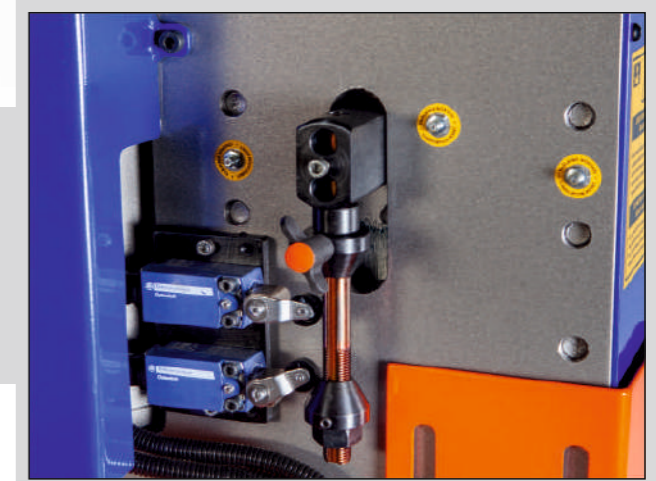

Telemecanique Siviçli Strok Ayar Sistemi
Stroke Adjustment System With Telemecanique Switch

BH-450 / HYD-450

HİDROLİK KESME & DELME MAKİNASI

HYDRAULIC CUTTING & PUNCHING MACHINE



Teknik Özellikler Technical Specifications

Makina Detayları / Machine Details		
Motor Gücü / Engine Power	kW	4
Motor Voltajı / Engine Voltage	V	380
Ağırlık / Weight	Kg	900
Makine Ölçüleri / Machine Dimensions	LxWxH mm	700x1050x1700
Hidrolik Kapasite / Hydraulic Capacity	kN	600
Çalışma Basıncı / Working Pressure	Bar	250
Strok / Stroke	mm	50

Köşebent Kesim / Section and Bar Stock Shear		
Kesit Alanı / Cross Section	Max. mm ²	1550
L Köşebent / L Angle Iron	mm	100 x 100 x 10
T Köşebent / T Angle Iron - Optional	mm	80 x 80 x 8
U Köşebent / U Angle Iron - Optional	mm	120 x 55
I Köşebent / I Angle Iron - Optional	mm	120 x 58
Yuvarlak / Round	mm	Ø 30
Kare / Square	mm	□ 28
Çalışma Yüksekliği / Working Height	mm	1200

Zımbalama / Punching Unit		
Zımbalama Çapı / Punching Diameter	mm	Ø30 in 15
Kurs Derinliği / Throat Depth	mm	160
Çalışma Yüksekliği / Working Height	mm	1250

Sac - Lama Kesim / Flat Bar Shear		
Lama Demir / Flat Bar	mm	300 x 15
Çalışma Yüksekliği / Working Height	mm	970

Çentik / Notcher		
Sac / Sheet Metal	Max. mm	8
Köşebent Demir / Angle Iron	mm	50 x 50 x 5
Kare Çentik Eni / Square Notch Width	mm	50
Kare Çentik Derinliği / Square Notch Depth	mm	50
Üçgen Çentik / Triangle Notcher (Optional)	mm	50 x 50 x 5
Çalışma Yüksekliği / Working Height	mm	1250

Bükme / Bending Tools (Opsiyonel/Optional)		
Lama / Flat	Max. mm	100 x 10
Bükme Ucu / Bending Punch	mm	60°, R=8
Bükme Kalıbı / Bending Die	mm	85°, R=8
Çalışma Yüksekliği / Working Height	mm	1250

- Flat bar shear blades, 310 mm wide, also shearing angle iron 45°
- Material Support table on the notcher station
- Material Support table on the flat bar shear station
- Material Support table on the punch unit
- Section shear station for shearing angle iron, rounds and squares.
- Easy-to-change punch & die set
- Foot switch and electrical controls
- Connecting socket for remote tripping, e.g. electrical length stop
- Hydraulic power-pack with a charge of fluid
- Three-phase A.C. motor 380V 50Hz
- All performance data are based on a tensile strength of 450 N/mm².

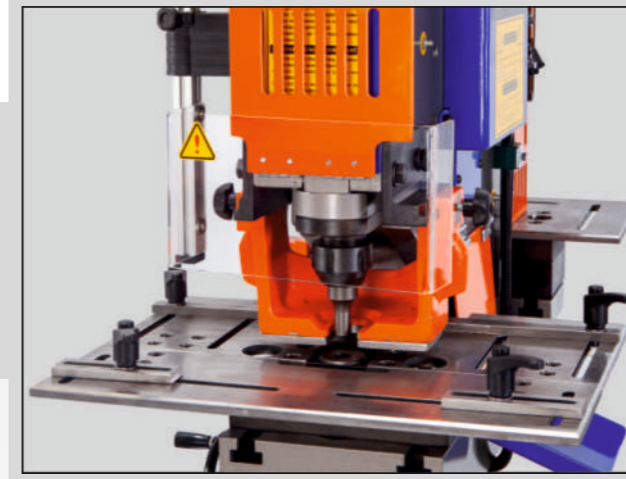

15mm Malzeme Kalınlığına Kadar Delik Delme Tablası
Punching Table Up To 15mm Material Thickness



Kare Ve Üçgen Çentik Açma Bölümü
Square And Triangle Notcher Section



Lama Kesim Ve 45° Köşebent Çentik Açma Bölümü
Flat Iron Cutting And 45° Angle Iron Notcher Section



Köşebent Ve Npu Kesim Bölümü
Angle Iron And Npu Cutting Section

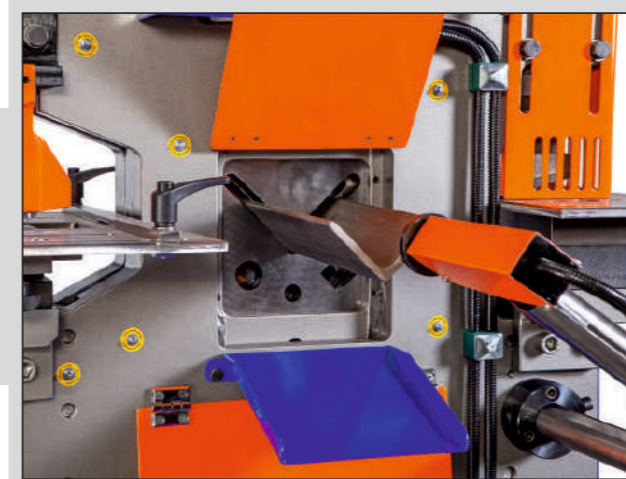

Cetveli Yarı-Otomatik Boy Kesme Aparatı
Semi-Automatic Length Cutting Apparatus With Ruler

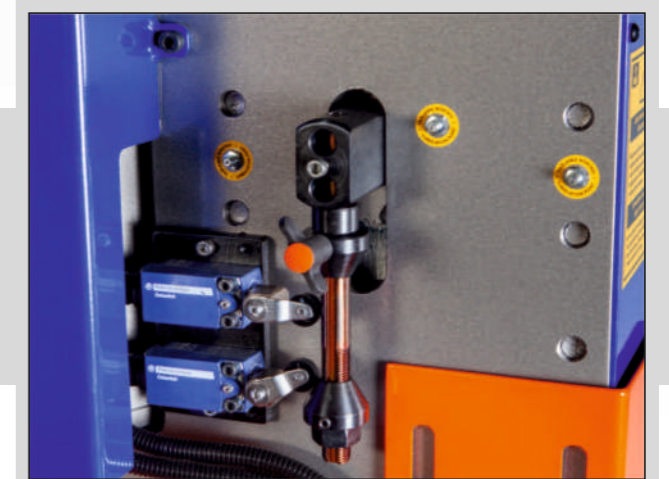

Telemecanique Siviçli Strok Ayar Sistemi
Stroke Adjustment System With Telemecanique Switch

BH-600 / HYD-2116

HİDROLİK DELME MAKİNASI

HYDRAULIC PUNCHING MACHINE



Teknik Özellikler Technical Specifications

Makina Detayları / Machine Details		
Motor Gücü / Engine Power	kW	4
Motor Voltajı / Engine Voltage	V	380
Ağırlık / Weight	Kg	620
Makine Ölçüleri / Machine Dimensions	LxWxH mm	610x810x1910
Hidrolik Kapasite / Hydraulic Capacity	kN	250
Çalışma Basıncı / Working Pressure	Bar	250
Strok / Stroke	mm	50

Zımbalama / Puncing Unit		
Zımbalama Çapı / Punching Diameter	mm	Ø 30 in 8 Ø 16 in 15
Kurs Derinliği / Throat Depth	mm	200
Çalışma Yüksekliği / Working Height	mm	1200
NPU ve NPI Zımbalama / Punching of Sections (Optional)		
NPI Yan Duvar / NPI on the leg	mm	80-140
NPI Sirt Duvar / NPI on the web	mm	80-140
NPU Yan Duvar / NPU on the leg	mm	65-140
NPU Sirt Duvar / NPU on the web	mm	65-140

- Material Support table on the punch unit
- Easy-to-change punch & die set
- Foot switch and electrical controls
- Hydraulic power-pack with a charge of fluid
- Three-phase A.C. motor 380V 50Hz
- All performance data are based on a tensile strength of 450 N/mm².

MODEL FARKLILIKLARI; MODEL DIFFERENCES;

BH-610 / HYD-2116-DB

HİDROLİK DELME MAKİNASI
HYDRAULIC PUNCHING MACHINE

Makina Detayları / Machine Details		
Boğaz Derinliği / Throat Depth	mm	370
Makine Ölçüleri / Machine Dimensions	mm	610x900x1910
Ağırlık / Weight	kg	700

Özel Projeler için Lütfen bilgi alınız.
Please contact for Special Projects.

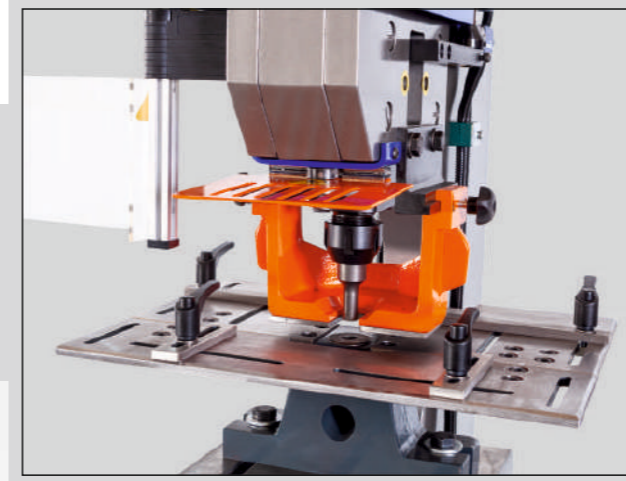

10mm Malzeme Kalınlığına Kadar Delik Delme Tablası
Punching Table Up To 10mm Material Thickness

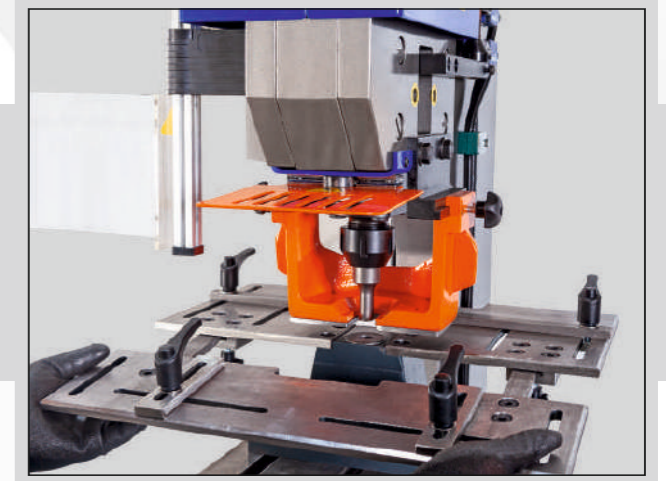

Çıkarılabilir Ön Tabla Tasarımı
Removable Front Table Design



Yarı-Otomatik Baskı Aparatı
Semi-Automatic Hold-Down Apparatus

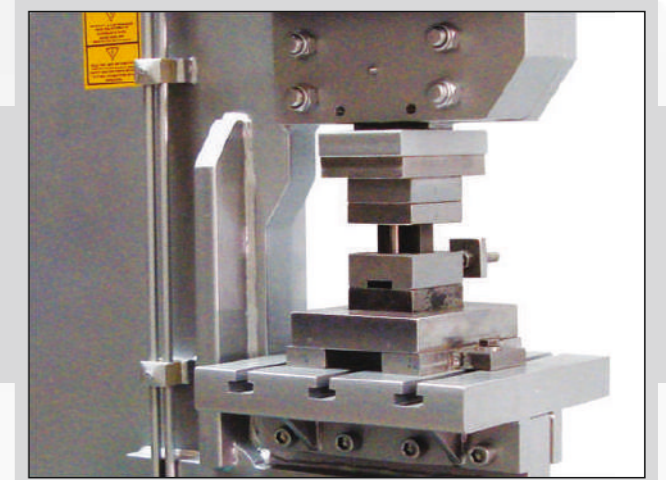

Özel Kelepçe Kesme Kalıbı
Special Clamp Cutting Mold

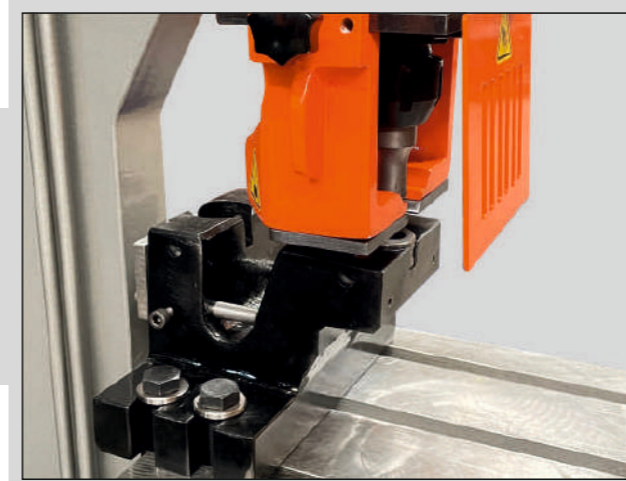

Npu Yan Ve Sirt Duvar Delme Kalıbı
Npu Web And Flange Punching Mold



12 Metreye Kadar Otomatik Servo Besleme Sistemi
Automatic Servo Feeding System Up To 12 Meters

BH-620 / IW-30

HİDROLİK PRES (C TİPİ)

HYDRAULIC PRESS (C TYPE)

Teknik Özellikler Technical Specifications

Makina Detayları / Machine Details		
Motor Gücü / Engine Power	kW	4
Motor Voltajı / Engine Voltage	V	380
Ağırlık / Weight	Kg	640
Makine Ölçüleri / Machine Dimensions	LxWxH mm	710x800x1900
Hidrolik Kapasite / Hydraulic Capacity	kN	300
Çalışma Basıncı / Working Pressure	Bar	250
Strok / Stroke	mm	100
Çalışma Hızı / Working Speed	mm/s	15

Zımbalama / Puncing Unit		
Zımbalama Çapı / Puncing Diameter	mm	Ø 30 in 10
		Ø 16 in 18
Kurs Derinliği / Throat Depth	mm	220
Çalışma Yüksekliği / Working Height	mm	1020
NPU ve NPI Zımbalama / Puncing of Sections (Optional)		
NPI Yan Duvar / NPI on the leg	mm	80-140
NPI Sirt Duvar / NPI on the web	mm	80-300
NPU Yan Duvar / NPU on the leg	mm	65-140
NPU Sirt Duvar / NPU on the web	mm	65-300

- Material Support table on the punch unit
- Easy-to-change punch & die set
- Foot switch and electrical controls
- Hydraulic power-pack with a charge of fluid
- Three-phase A.C. motor 380V 50Hz
- All performance data are based on a tensile strength of 450 N/mm².

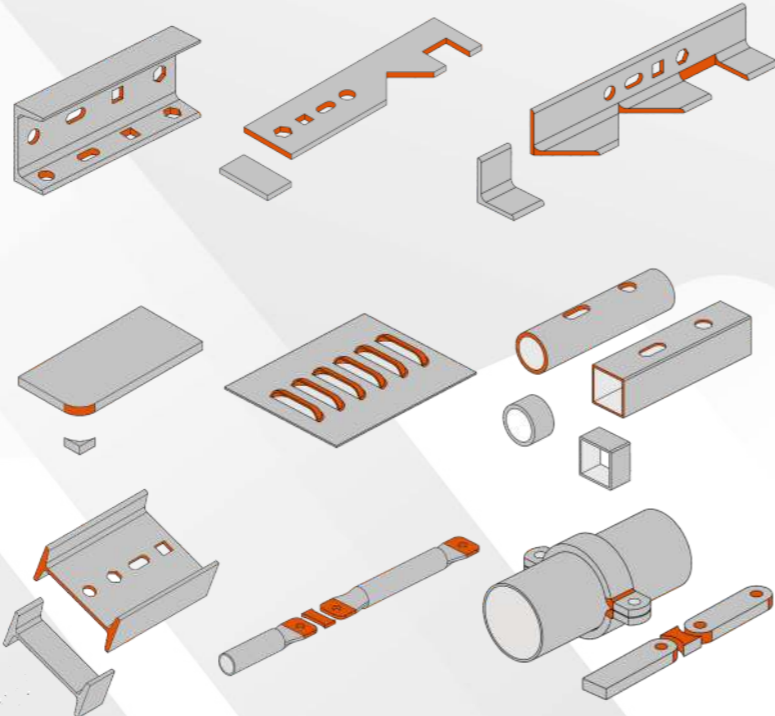

ÖZEL KALIPLAR İÇİN LÜTFEN BİLGİ ALINIZ

Please contact for Special Tools.

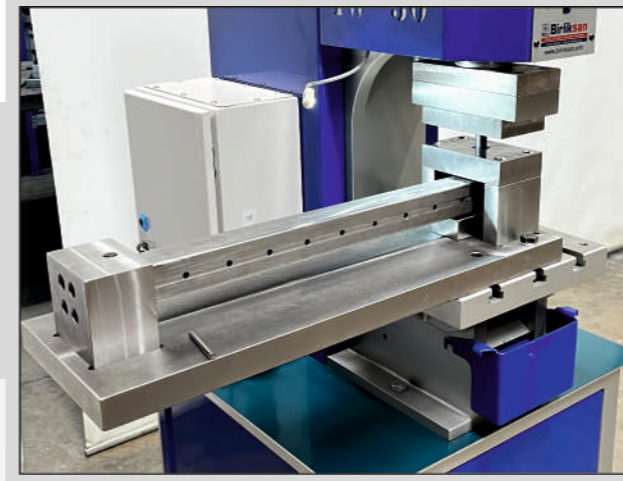

80x80x4mm'e Kadar Profil Delme Kalıbı
Profile Puncing Mold Up To 80x80x4mm



Farklı Delik Çaplarında Boru Delme Kalıbı
Pipe Puncing Mold For Different Hole Diameters

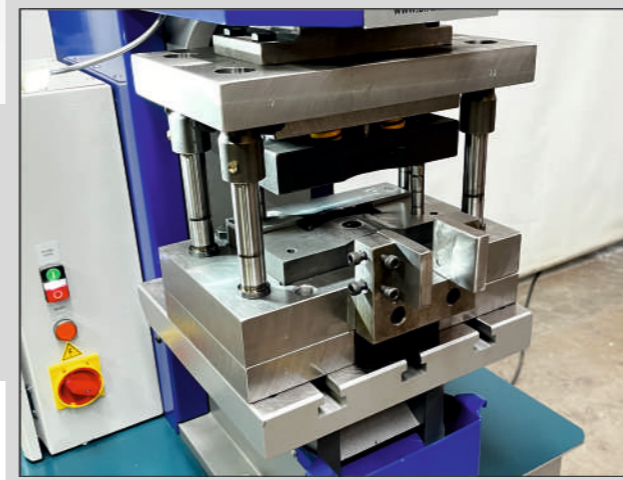

Boru Ezme Ve Delme Kalıbı
Pipe Flattening And Puncing Mold

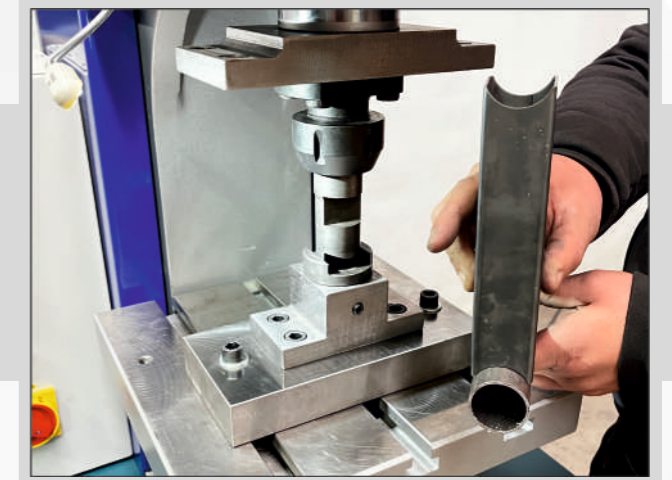

Profil Çentik Kalıbı
Profile Notcher Mold

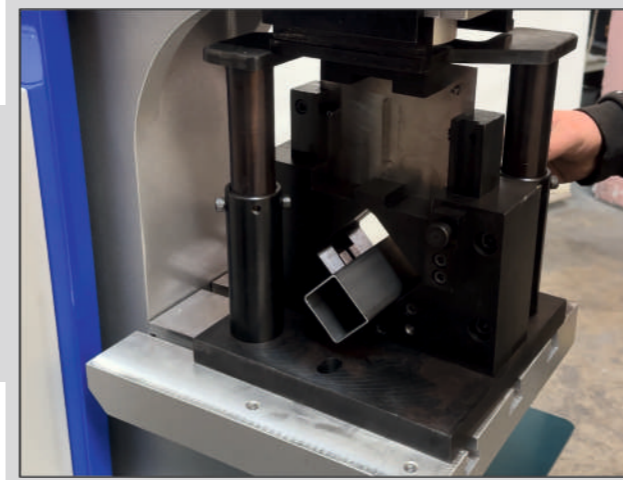

60x60x3mm'e Kadar Profil Kesme Kalıbı
Profile Cutting Mold Up To 60x60x3mm

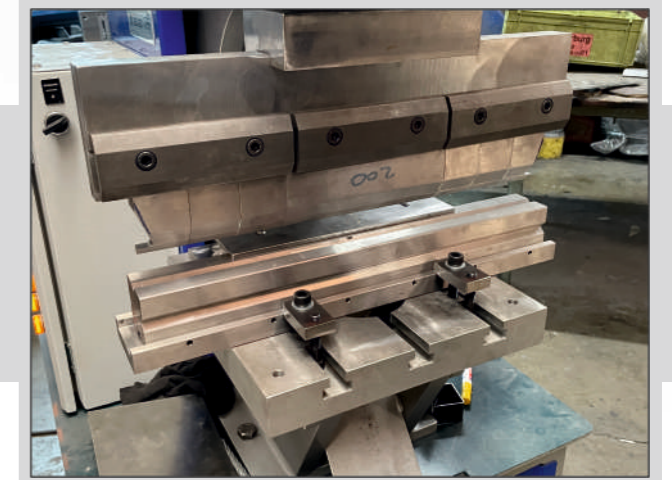

50cm'e Kadar Sac Bükme Kalıbı
Sheet Bending Mold Up To 50cm

BH-630 / IW-60

HİDROLİK KESME VE DELME MAKİNESİ

HYDRAULIC CUTTING & PUNCHING MACHINE



Teknik Özellikler Technical Specifications

Makina Detayları / Machine Details		
Motor Gücü / Engine Power	kW	4
Motor Voltajı / Engine Voltage	V	380
Ağırlık / Weight	Kg	1600
Makine Ölçüleri / Machine Dimensions	LxWxH cm	120x100x215
Hidrolik Kapasite / Hydraulic Capacity	kN	600
Çalışma Basıncı / Working Pressure	Bar	230
Strok / Stroke	mm	120
Çalışma Hızı / Working Speed	mm/s	12

Zımbalama / Puncing Unit		
Zımbalama Çapı / Punching Diameter	mm	Ø 30 in 15
		Ø 22 in 20
Kurs Derinliği / Throat Depth	mm	350
Çalışma Yüksekliği / Working Height	mm	1000

NPU ve NPI Zımbalama / Punching of Sections (Optional)		
NPI Yan Duvar / NPI on the leg	mm	80-240
NPI Sirt Duvar / NPI on the web	mm	80-300
NPU Yan Duvar / NPU on the leg	mm	65-240
NPU Sirt Duvar / NPU on the web	mm	65-300

- 7" Display PLC control panel
- Linear ruler for stroke control
- Pressure and hydraulic oil level indicator
- Pressure control switch
- Material support table on the punch unit
- Easy-to-change punch & die set
- Foot switch and electrical controls
- Hydraulic power-pack with a charge of fluid
- Three-phase A.C. motor 380V 50Hz
- All performance data are based on a tensile strength of 450 N/mm².

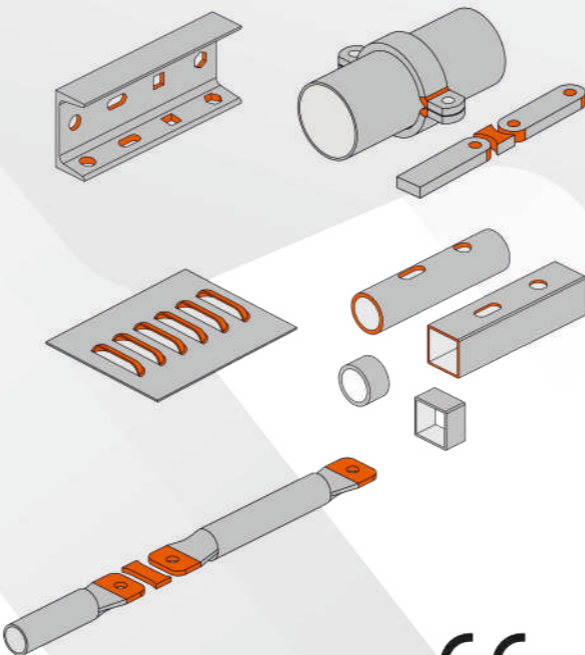

CE

Teknik Özellikler Technical Specifications

Makina Detayları / Machine Details		
Motor Gücü / Engine Power	kW	2.2
Motor Voltajı / Engine Voltage	V	380
Ağırlık / Weight	Kg	320
Makine Ölçüleri / Machine Dimensions	LxWxH mm	750x600x1600
Hidrolik Kapasite / Hydraulic Capacity	kN	200
Çalışma Basıncı / Working Pressure	Bar	200
Strok / Stroke	mm	30
Çalışma Hızı / Working Speed	mm/s	16

Zımbalama / Puncing Unit		
Zımbalama Çapı / Punching Diameter	mm	Ø 26 in 8
		Ø 16 in 10
Kurs Derinliği / Throat Depth	mm	90
Çalışma Yüksekliği / Working Height	mm	1020

NPU ve NPI Zımbalama / Punching of Sections (Optional)		
NPI Yan Duvar / NPI on the leg	mm	80
NPI Sirt Duvar / NPI on the web	mm	80-160
NPU Yan Duvar / NPU on the leg	mm	65
NPU Sirt Duvar / NPU on the web	mm	65-160

- Material Support table on the punch unit
- Easy-to-change punch & die set
- Foot switch and electrical controls
- Hydraulic power-pack with a charge of fluid
- Three-phase A.C. motor 380V 50Hz
- All performance data are based on a tensile strength of 450 N/mm².

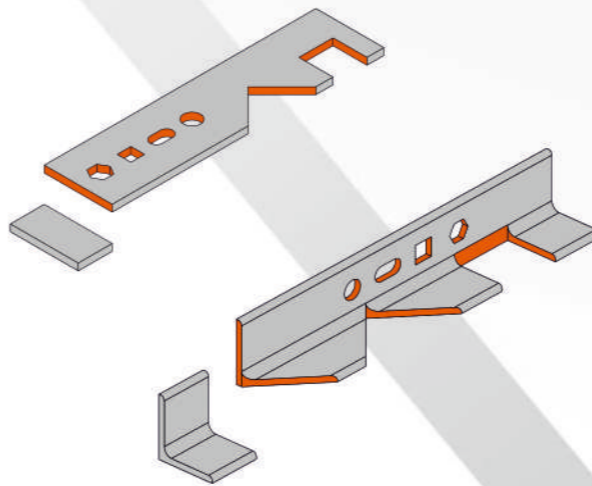

CE

BH-615 / IW-15

HİDROLİK DELME MAKİNESİ

HYDRAULIC PUNCHING MACHINE



ÖZEL KALIPLAR İÇİN LÜTFEN BİLGİ ALINIZ.

Please contact for Special Tools.

ÖZEL KALIPLAR İÇİN LÜTFEN BİLGİ ALINIZ.

Please contact for Special Tools.

BH-526 / HYD-526

HİDROLİK KESME MAKİNESİ

HYDRAULIC CUTTING MACHINE



Teknik Özellikler Technical Specifications

Makina Detayları / Machine Details		
Motor Gücü / Engine Power	kW	2.2
Motor Voltajı / Engine Voltage	V	380
Ağırlık / Weight	Kg	280
Makine Ölçüleri / Machine Dimensions	LxWxH mm	750x520x1440
Hidrolik Kapasite / Hydraulic Capacity	kN	300
Çalışma Basıncı / Working Pressure	Bar	200
Strok / Stroke	mm	30
Çalışma Hızı / Working Speed	mm/s	15
Sac - Lama Kesim / Flat Bar Shear		
Lama Demir / Flat Bar	mm	100 x 10
Çalışma Yüksekliği / Working Height	mm	880
Köşebent Kesim / Section and Bar Stock Shear		
Yuvarlak / Round	mm	Ø26
Kare / Square	mm	18
Çalışma Yüksekliği / Working Height	mm	880

- Material Support table on the punch unit
- Easy-to-change blade set
- Foot switch and electrical controls
- Hydraulic power-pack with a charge of fluid
- Three-phase A.C. motor 380V 50Hz
- All performance data are based on a tensile strength of 450 N/mm².

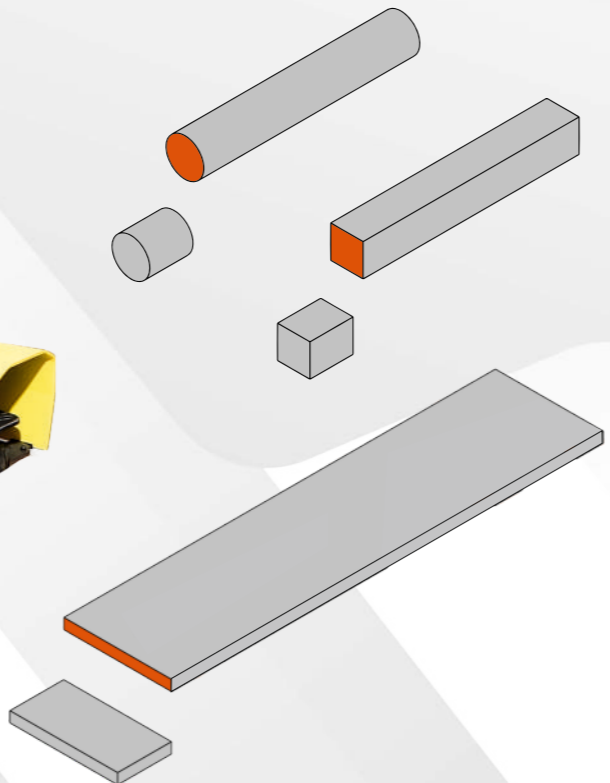

ÖZEL KALIPLAR İÇİN LÜTFEN BİLGİ ALINIZ

Please contact for Special Tools.



OPSİYONEL APARATLAR

OPSİYONEL BIÇAKLAR VE ZIMBA TAKIMLARI

OPTIONAL BLADES AND PUNCH & DIE SETS



Yuvarlak Zimba Takımları (Ø40mm'e kadar)
Round punch sets (up to Ø40mm)



Slot Zimba Takımları (Slot Uzunluğu 40mm'e Kadar)
Oblong Punch Sets (Oblong Length up to 40mm)



Zimba Somunları
Punch Nuts



Özel Slot Zimba Takımları (50mm'e kadar)
Special Oblong Punch Sets (up to 50mm)

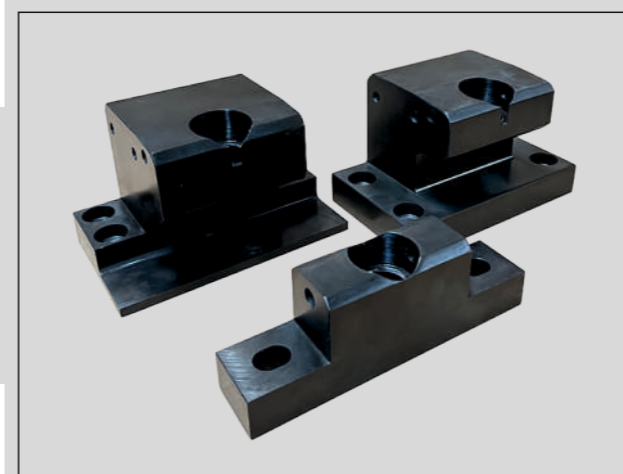

Npu Yan Ve Sirt Duvar Delme Kalibi
Npu Web And Flange Punching Mold

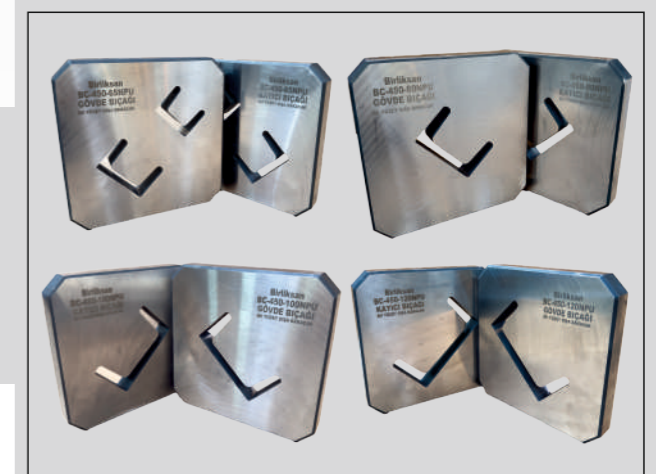

NPU Biçakları (120NPU'ya kadar)
NPU Blades (up to 120NPU)

MBK-3000

MAKARALI BESLEME KONVEYÖRÜ

ROLLER FEED CONVEYOR



HAREKETLİ MEKANİZMA
MOVEABLE MECHANISM

Teknik Özellikler Technical Specifications

Makina Detayları / Machine Details		
Dış Ölçüler / Dimensions (LxW)	mm	300 x 3000
Maksimum Yükseklik / Max. Height (H)	mm	1300
Minimum Yükseklik / Min. Height (H)	mm	300
Kapasite / Capacity	kg	500
Ağırlık / Weight	kg	190

Kullanılabilen Ürünler / Used Materials

L Köşebent / L Angle Iron
U Köşebent / U Angle Iron
Lama / Flat Iron

Konfigürasyonlar / Configurations

U Köşebent Zimba Aparatı / Punching Apparatus for U Angle Iron
Motor Kontrollü Yükseklik Ayarı / Height Control Via Electrical Motor
4'er Adet Lama Sürme ve Köşebent Sürme Makarası / 4 Pcs. Feeding Roller for Flat Iron and Angle Iron.
PLC Kontrollü Otomatik Besleme / Automatic Feed with PLC Controlled

Özel Projeler için lütfen bilgi alın.
Please contact for Special Projects.



Köşebent Ve Npu Besleme İçin Makaralar
Feeding Rollers For Angle Iron and NPU



Lama Besleme İçin Makaralar
Feeding Rollers For Flat Iron



Aşağı Ve Yukarı Hareketi Sağlayan Makas Sistemi
Mechanism For Moving Up And Down

BH-640 / PW-10

HİDROLİK PROFİL ÇENTİK PRESİ

HYDRAULIC PROFILE NOTCHER PRESS

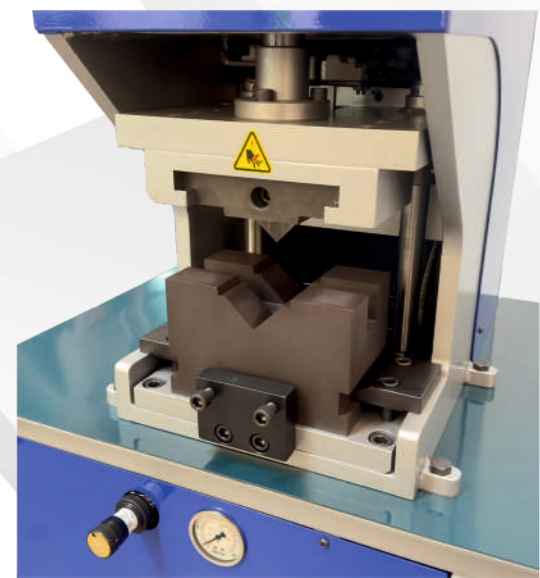

Teknik Özellikler Technical Specifications

Makina Detayları / Machine Details		
Motor Gücü / Engine Power	kW	4
Motor Voltajı / Engine Voltage	V	380
Ağırlık / Weight	Kg	430
Makine Ölçüleri / Machine Dimensions	LxWxH mm	840x640x1580
Hidrolik Kapasite / Hydraulic Capacity	kN	100
Çalışma Basıncı / Working Pressure	Bar	200
Strok / Stroke	mm	100
Çalışma Hızı / Working Speed	mm/s	30
Çalışma Yüksekliği / Working Height	mm	1050
Maks. Profil Ebatı / Max. Profile Dimension	mm	50x50x1,5

- Foot switch and electrical controls
- Hydraulic power-pack with a charge of fluid
- Three-phase A.C. motor 380V 50Hz
- All performance data are based on a tensile strength of 450 N/mm².
- Standard machine includes one profile dimension mold according to your demand.

Birlüksan Hydraulic Ironworkers are able to;

► KESİM / CUTTING

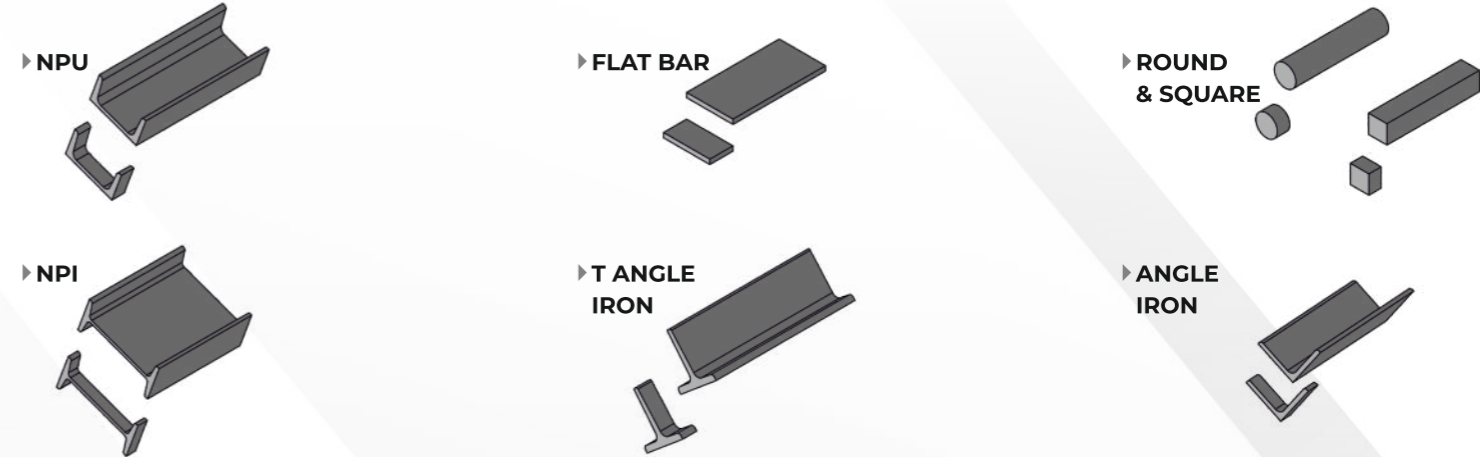

► ZİMBALAMA / PUNCHING

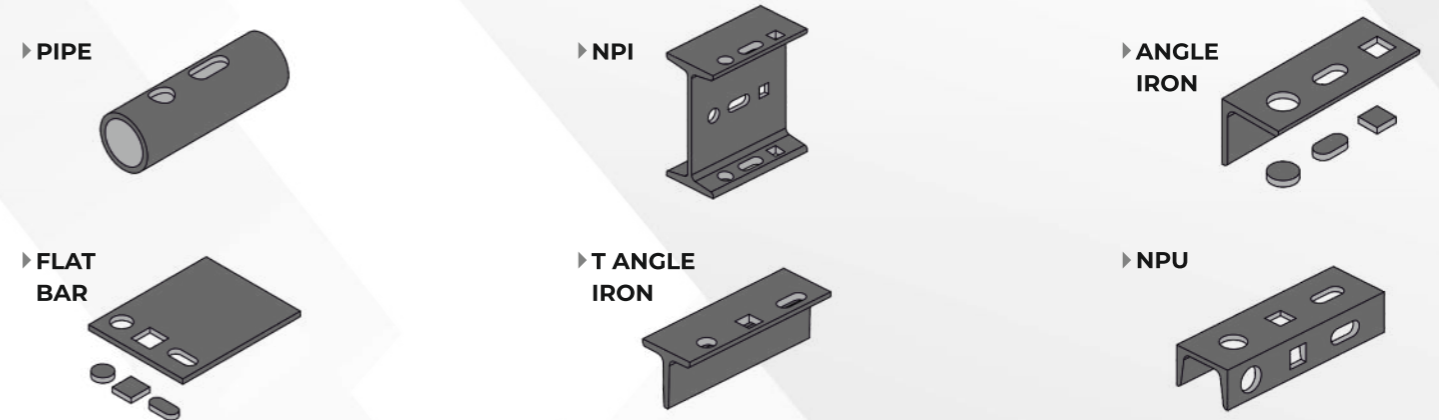

► ÇENTİK & BÜKME / NOTCHING & BENDING

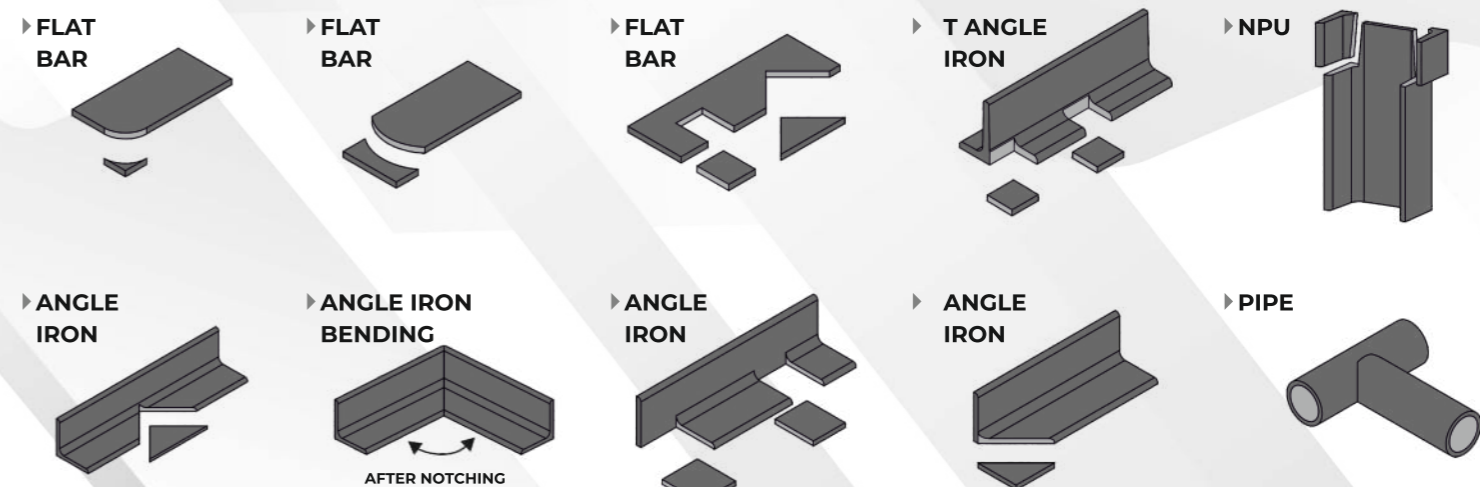

Özel Projeler için lütfen bilgi alın. / Please contact for Special Projects.



Birlüksan®

METAL CUTTING & PUNCHING MACHINES

METAL KESME ve DELME MAKİNALARI

🏠 Fevzi Çakmak Mahallesi
10614. Sokak No.35
Karatay / KONYA / TÜRKİYE

✉ info@birlüksan.com
bilgi@birlüksan.com.tr

🌐 www.birlüksan.com

☎ +90 332 342 68 81-82-83